



Barcode: 5060452080765

transbank chem™

Product code: TRB2C

- » Fully welded unit, for storing and transporting hazardous liquids.
- » Suitable for vehicle mounting in line with regulations.
- » Designed for storing 2 x 20 litre cans.



Product features



Padlock secured



COSHH compliant



Sump capacity



Fire resistant



No detachable parts



Safety signage



Suitable for vehicles

Product specifications

| | |
|----------------------------|---------------------------------------|
| Weight | 20kg |
| Colour | Traffic yellow: RAL 1023 |
| Suitable for | Transporting chemicals - 2 x 20L cans |
| Finished coating | Powder coated |
| Material & thickness | 1.2mm steel |
| Quantity of keys | No |
| How are castors fitted? | Not applicable |
| Other sizes available | 2 other sizes |
| Ventilation | Yes |
| Qty of shelves as standard | Not applicable |

Dimensions

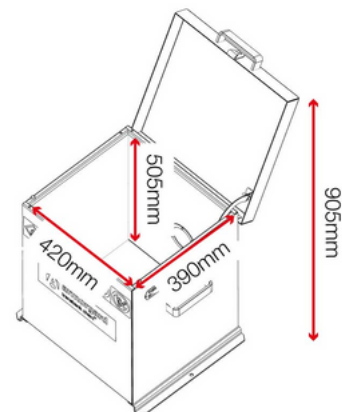
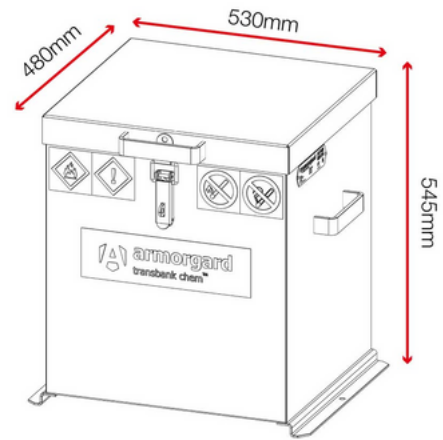

Optional extras



Padlock LOCK-P50



Barcode: 5060452080772

transbank chem™

Product code: TRB4C

- » Fully welded unit, for storing and transporting hazardous liquids.
- » Suitable for vehicle mounting in line with regulations.
- » Designed for storing 4 x 20 litre cans.

Product features



Padlock secured



COSHH compliant



Sump capacity



Fire resistant



No detachable parts



Safety signage



Suitable for vehicles

Product specifications

| | |
|----------------------------|---------------------------------------|
| Weight | 28kg |
| Colour | Traffic yellow: RAL 1023 |
| Suitable for | Transporting chemicals - 4 x 20L cans |
| Finished coating | Powder coated |
| Material & thickness | 1.2mm steel |
| Quantity of keys | No |
| How are castors fitted? | Not applicable |
| Other sizes available | 2 other sizes |
| Ventilation | Yes |
| Qty of shelves as standard | Not applicable |

Dimensions

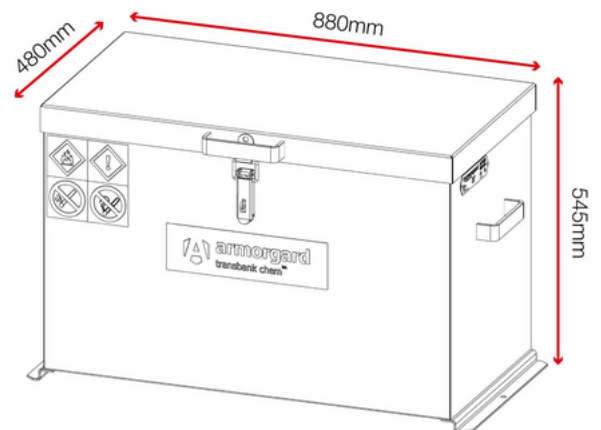

Optional extras



Padlock LOCK-P50

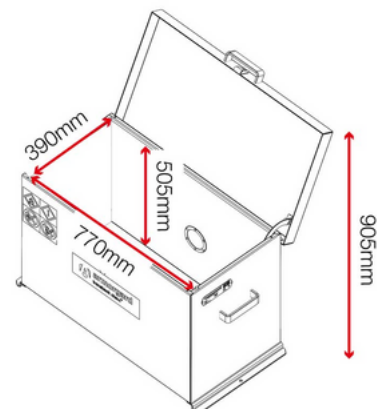



Barcode: 5060452080758

transbank chem™

Product code: TRB1C

- » Fully welded unit, for storing and transporting hazardous liquids.
- » Suitable for vehicle mounting in line with regulations.
- » Designed for storing 2 x 5 litre cans.



Product features



Padlock secured



COSHH compliant



Sump capacity



Fire resistant



No detachable parts



Safety signage



Suitable for vehicles

Product specifications

| | |
|----------------------------|--------------------------------------|
| Weight | 13kg |
| Colour | Traffic yellow: RAL 1023 |
| Suitable for | Transporting chemicals - 2 x 5L cans |
| Finished coating | Powder coated |
| Material & thickness | 1.2mm steel |
| Quantity of keys | No |
| How are castors fitted? | Not applicable |
| Other sizes available | 2 other sizes |
| Ventilation | Yes |
| Qty of shelves as standard | Not applicable |

Dimensions

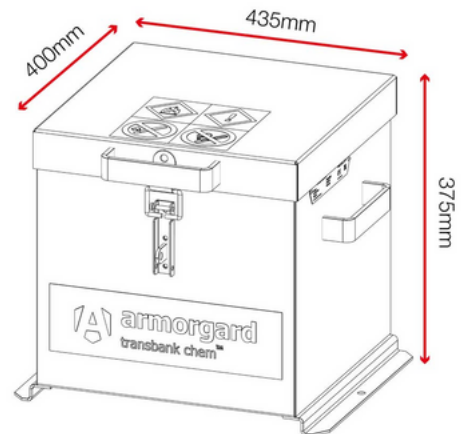

Optional extras



Padlock LOCK-P50

